



HUMER®



BROCHURE 2025



debon-trailers.com



SINGLE AXLE BOX VAN TRAILER



Roadster 220

Roadster 255
Unbraked Version

Roadster 255
Braked version

Cargo 1300

Roadster 300

Roadster 400

Payload	420 kg	400 kg	930 kg	855 kg	840 kg	810 kg
Ramp's weight capacity	No ramp	500 kg	500 kg	500 kg 750 kg (as extra)	500 kg 750 kg (as extra)	500 kg 750 kg (as extra)
Pullman	No	No	No	Yes	Yes	Yes
External dimensions (LxIxh) en mm	3510x1610x1801	3690x1740x2010	3690x1740x2010	4250x2020x2020	4250x2050x2310	4450x2150x2370
Max. Gross Weight	750 kg	750 kg	1300 kg	1300 kg	1300 kg	1300 kg
Interior dimensions (LxIxh) en mm	2200x1080x1150	2550x1250x1550	2550x1250x1550	3000x1520x1650	3000x1650x1520	3130x1660x2010
Floor	non-slip plywood	non-slip plywood 15 mm	non-slip plywood 15 mm	non-slip plywood 15 mm	non-slip plywood 15 mm	Aluminium 24 mm 5 years warranty
Galvanised steel chassis with aluminum extrusion framework	Yes	Yes	Yes	Yes	Yes	Yes
Wheel chocks	Yes	Yes	Yes	Yes	Yes	Yes
Interior light	No	No	No	Yes	Yes	Yes
Rear loading	Opening door	Ramp-door	Ramp-door	Ramp-door	Ramp-door	Ramp-door

DOUBLE AXLE BOX VAN TRAILER



Roadster 500

Roadster 700

Roadster 800

Roadster 900

Roadster 1000

Roadster 2000

1345 kg	1895 kg	2500 kg	2400 kg	2535 kg	2200 kg
500 kg 750 kg (as extra)	1000 kg	1000 kg	1000 kg	1500 kg	1500 kg
Yes	Yes	Yes	Yes	Yes	Yes
4450x2150x2370	4990x2330x2370	5650x2315x2440	6220x2315x2440	6250x2345x2365	6750x2530x2480
2600 kg (2600 kg as extra)	2600 kg	3500 kg	3500 kg	3500 kg	3500 kg
3130x1660x2010	3760x1810x2010	4360x2060x2060	4970x2060x2060	4970x2020x2060	5500x2200x2045
Aluminium 24 mm 5 years warranty	Aluminium 24 mm 5 years warranty	Aluminium 24 mm 5 years warranty	Aluminium 24 mm 5 years warranty	Aluminium 24 mm 5 years warranty	Aluminium 24 mm 5 years warranty
Yes	Yes	Yes	Yes	Yes	Yes
Yes	Yes	Yes	Yes	Yes	Yes
Yes	Yes	Yes	Yes	Yes	Yes
Ramp-door	Ramp-door	Ramp-door	Ramp-door	Ramp with ramp extension	Ramp with ramp extension



ROADSTER 220

Plywood



- Hot dip galvanized chassis
- Lockable rear door
- 2 wheel chocks
- jockey wheel diameter 48mm
- Axle 750 kg unbraked
- Protected lights
- “V” drawbar
- Tie-rings x4
- 1 handle
- 1 prop stand



RAMP DOOR
COMBINATION



ROADSTER 255

braked trailer

Composite



Fiberglass



Aluminium 5 years
warranty



- Roof and front in one solid fiberglass part
- 18 mm plywood side walls
- Aluminium rear ramp door combination
- Shockproof mudguards
- Protected lights
- Tie-rings x4
- 2 prop stands
- Automatic jockey wheel with handle

OPTIONAL

- Composite side walls
- Aluminium side walls
- Lateral door with key lock





ROADSTER 255

Unbraked Trailer

Plywood



Fiberglass



- Roof and front in one solid fiberglass part
- 18 mm plywood side walls
- Aluminium rear ramp door combination
- Shockproof mudguards
- Protected lights
- Tie-rings x4
- 2 prop stands
- Automatic jockey wheel

OPTIONAL

- Side door with key lock



RAMP DOOR
COMBINATION



Our vans crafted for all drivers.

With these models, you don't need a special licence. Designed to be **compact** and lightweight, these vans combine **robustness** and **manoeuvrability** for a **pleasant drive**, even for beginners



Simple. Efficient. Unlimited.

Book a trial today and discover the Debon difference.

ROADSTER 300

PULLMAN 2
performance

RAMP DOOR
COMBINATION

Composite



Fiberglass



Aluminium 5 years
warranty



- Roof and front in one solid fiberglass part
- Plywood side walls 18 mm with UV protection folder
- Aluminium ramp door combination
- Shockproof mudguards
- Protected lights
- Tie-rings x4
- 2 pro stands
- Automatic jockey with handle

OPTIONAL

- Aluminium side walls
- Lateral door with key lock
- Lateral sales flap.



CARGO 1300

PULLMAN 2
performance

RAMP DOOR
COMBINATION

Fiberglass



- Fiberglass bodywork
- Exclusive aerodynamic design
- Rear aluminium ramp door combination
- Shockproof mudguards
- Protected lights
- Tie-rings x4
- 2 prop stands
- Automatic jockey wheel with handle

OPTIONAL

- Side door with key lock





ROADSTER 400

PULLMAN²
performance

Composite



Fiberglass



- Roof and front in one solid fiberglass part
- 18 mm plywood side walls
- Aluminium floor
- Aluminium rear ramp door combination.
- Shockproof mudguards
- Protected lights
- Tie-rings x4
- 2 prop stands
- Automatic jockey wheel with handle

OPTIONAL

- Aluminium side walls
- Lateral door with key lock
- Lateral sales flap



RAMP DOOR
COMBINATION



PULLMAN²
performance

Pullman technology, the Debon difference.

A flagship **innovation** for our trailers, the **Pullman suspension** system significantly improves driving comfort by reducing while maintaining **stability** and **safety**, even when fully loaded.

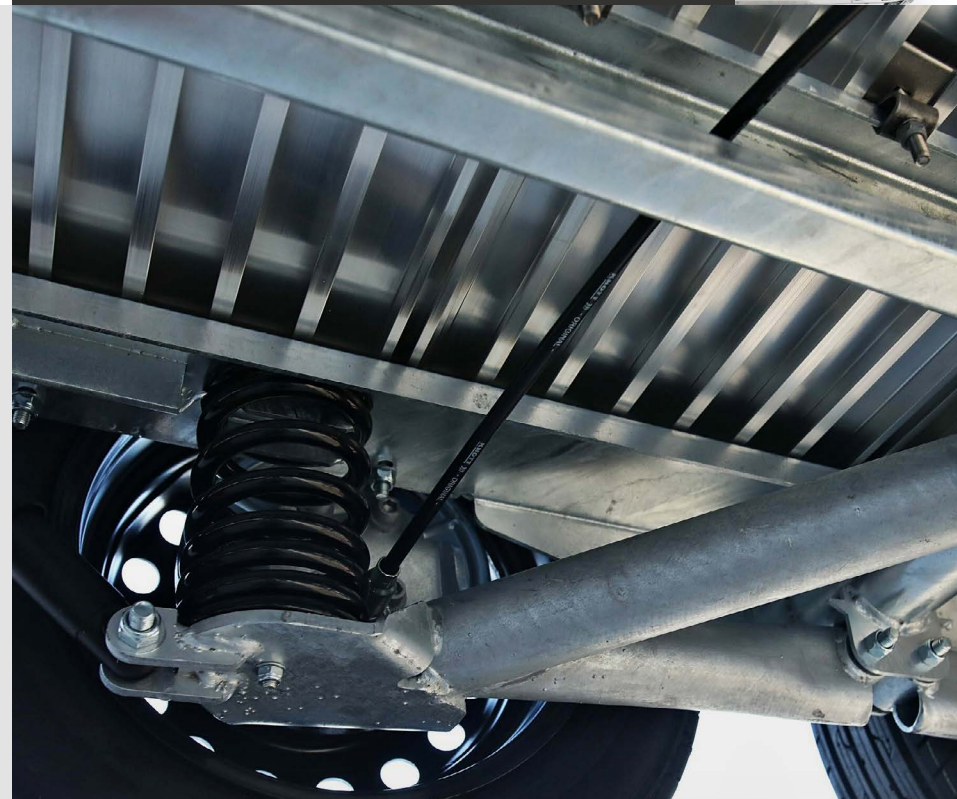

ROADSTER 500

PULLMAN 2
performance

Composite



Fiberglass



- Roof and front in one solid fiberglass part
- 18 mm plywood side walls
- Aluminium floor
- Rear aluminium ramp door combination
- Shockproof mudguards
- Protected lights
- Tie-rings x6
- Automatic jockey wheel with handle

OPTIONAL

- Aluminium side walls
- Lateral door with key lock
- Lateral sales flap

RAMP DOOR
COMBINATION

LATERAL SALES FLAP



ROADSTER 700

PULLMAN 2
performance

Fiberglass



- Roof and front in one solid fiberglass part
- Aluminium side walls
- Aluminium floor
- Rear aluminium ramp door combination
- Lateral door with key lock
- Shockproof mudguards
- Protected lights
- Tie-rings x8
- Wheels 14"
- Automatic jockey wheel with handle

OPTIONAL

- Lateral sales flap

RAMP DOOR
COMBINATION





ROADSTER 800 ROADSTER 900

PULLMAN²
performance

Fiberglass



- Roof and front in one solid fiberglass part
- Aluminum lateral walls and floor
- Rear aluminium ramp door combination
- Lateral door with key lock
- Shockproof mudguards
- Designed rear lamps
- Tie-rings x8
- Automatic jockey wheel with handle
- Wheels 14"

OPTIONAL

- Lateral sales flap



Your trailer tailored to fit your needs on the spot

With a variety of opening options, our trailers give you total flexibility for transporting, accessing and organising your equipment.



Lateral doors L/R



Ramp door combination (model 255 to 900)

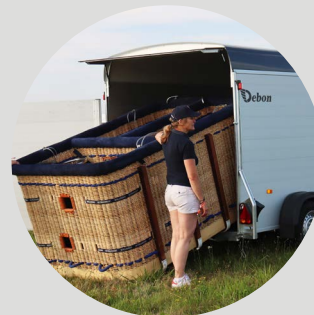

Lateral sales flap



ROADSTER 1000

VEHICLE TRANSPORT



Fiberglass



- Roof and front in one solid fiberglass part
- Honeycomb composite side walls
- Aluminium ramp with ramp extension
- 2 lateral doors
- 2 Side flaps : width 2360mm x height 1320mm
- Shockproof mudguards
- Led lights
- Tie-rings x8
- Automatic jockey wheel
- Low-profile tires 13'
- Prop stands

OPTIONAL

- Slidding electric winch
- Leveling ramps +11cm



RAMP DOOR COMBINATION



ROADSTER 2000

VEHICLE TRANSPORT



Fiberglass



- Roof and front in one solid fiberglass part
- Aluminium side walls and floor
- Rear aluminium ramp
- 2 lateral doors
- 2 Side flaps : width 2360mm x height 1320mm
- Shockproof mudguards
- Led lights
- Tie-rings x8
- Automatic jockey wheel
- Low-profile tires 12'
- Prop stands

OPTIONAL

- Slidding electric winch
- Leveling ramps +11cm





Stability. Safety. Performance.

Thanks to the **Pullman technology**, which **protects** your cars from vibrations and shocks throughout the journey, the **Roadster 1000 and 2000** are guaranteed with **optimum transport** for your vehicles.



PULLMAN **2**
performance



ROADSTER GARDEN

Automatic tilting & secured locking

- V drawbar 1300 kg capacity
- Axles 750kg or 1350kg
- Jockey wheel
- Strong mudguards
- Tilting platform with gas damper assistance
- Strong ramp
- Many tying points

USEFUL DIMENSIONS

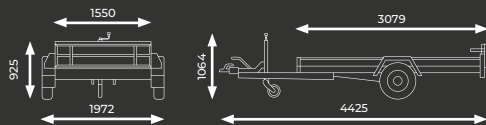

MODEL 150

Unladen weight = 275 kg (from)
Max. Gross Weight = 500 to 1200 kg

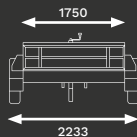

MODEL 175

Unladen weight = 372 kg (from)
Max. Gross Weight = 750 to 1300 kg



ROADSTER PLATFORM

Automatic tilting & secured locking

- V drawbar 1300kg
- Axle 750kg or 1350kg
- Jockey wheel
- Strong mudguards
- Tilting platform with gas damper assistance
- Anti slipping plywood floor
- Many tying points

USEFUL DIMENSIONS

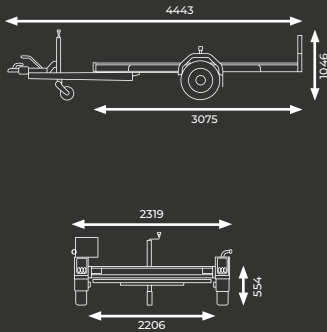

Unladen weight = 270 kg (from)
Max. Gross Weight = 500 to 1300 kg
depending on braked category



ROADSTER MOTO

Automatic tilting & secured locking

- Strong axle
- Jockey wheel
- Easy and safe loading/unloading for large and or heavy motorcycle
- Foot locking/unlocking pedal
- Adjustable for any tire dimensions
- Many tying points

USEFUL DIMENSIONS

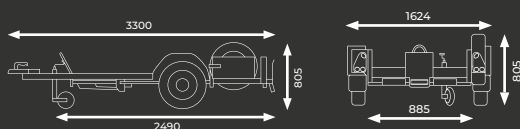

Roadster Moto 1 Dimension

Unladen weight = 185 kg (from)
Max. Gross Weight = 500, 600 ou 750 kg

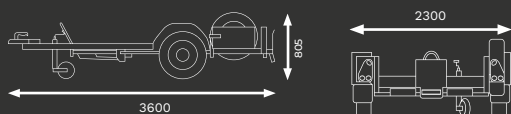

Roadster Moto 2 Dimension

Unladen weight = 355 kg (from)
Max. Gross Weight = 750 to 1300 kg



Roadster Moto 1



Roadster Moto 2

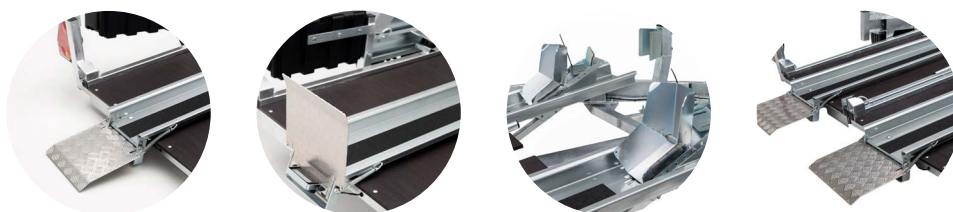

ROADSTER CAMP

- Hot dip galvanized chassis and parts.
- Aluminium anti slipping platform
- Jockey wheel
- Strong wheels with tires 195/50 B10 "High Speed Trailer"
- Adjustable platform to load 1 mortorcycle or several bikes.
- Extra removable rack to place more material or bikes.

USEFUL DIMENSIONS

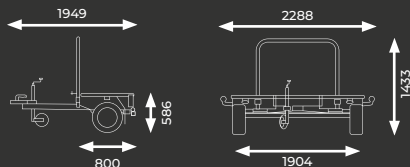

Unladen weight :
180 kg (from)

PTAC :
500 or 750 kg



ROADSTER AUTO

- Tilting platform with additional ramps.
- Robust construction, hot dipped galvanised.
- Progressive tilting with gas damper.
- Many tying possibilities.
- Ideal for transporting small vehicles.

Available optionals :

- Spare wheel with bracket
- Manual winch with bracket
- Tie straps and wheel chocks

USEFUL DIMENSIONS

Unladen weight = 360 kg (from)
Max. Gross Weight = 1 300 kg

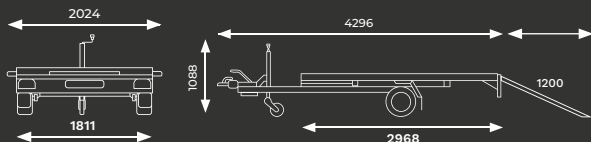

PWO

ONE-WAY TIPPER

- Hot dip galvanized chassis
- Strong axle
- 18 mm plywood floor
- Removable aluminium drop sides 300 mm
- Heavy duty automatic jockey wheel
- Protected front and rear lights
- Rectangular posts (no residue in the corners)

PWO «ECO»

- Double acting hand pump

PWO «LUX»

- Electro-hydraulic with battery
- Plywood floor with galvanised protection steel plate
- H-frame and 6 tie-rings

USEFUL DIMENSIONS

PWO

Unladen weight = 430 kg (from)
Max. Gross Weight = 750 to 1500 kg
 as required

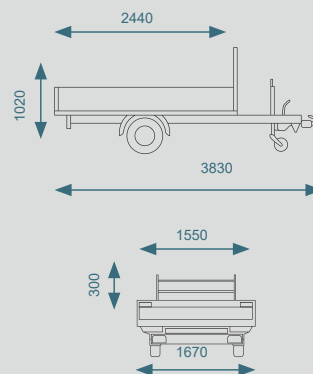

Model presented with a tarpaulin



Model shown with an extra set of side panels



Model shown with a mesh extension

PW1.2

ONE-WAY TIPPER

- Hot dip galvanized chassis
- 2 strong axles
- 18 mm plywood floor
- Removable aluminium drop sides 300 mm
- Heavy duty automatic jockey wheel
- Protected front and rear lights
- Rectangular posts (no residue in the corners)

PW1.2 «ECO»

- Double acting hand pump

PW1.2 «LUX»

- Electro-hydraulic with battery
- Plywood floor with galvanised protection steel plate
- H-frame and 6 tie-rings

PW1.2

Unladen weight = 540 kg (from)
Max. Gross Weight = 1100 to 2000 kg
 as required

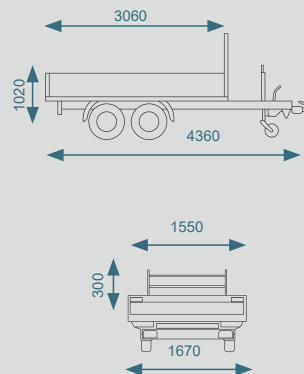



Model shown with an extra set of side panels



Model shown with a mesh extension, aluminium crutches and handrails

USEFUL DIMENSIONS

PW2.4

Unladen weight = 710 kg (from)
Max. Gross Weight = 1600 to 2600 kg
 as required

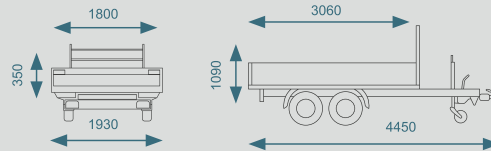

PW3.3

Unladen weight = 800 kg (from)
Max. Gross Weight = 2700 to 3500 kg
 as required

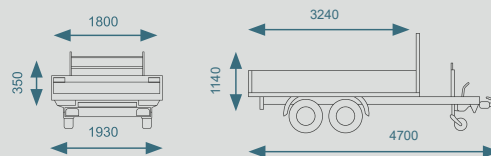

PW3.6

Unladen weight = 800 kg (from)
Max. Gross Weight = 2700 to 3500 kg
 as required

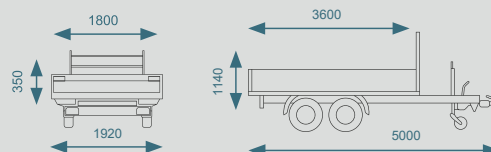

PW2.4 PW3.3 & PW3.6 THREE-WAY TIPPERS

PW2.4

- Hot dip galvanized chassis
- 2 strong axles
- 18 mm plywood floor with galvanised protection steel plate
- Heavy duty automatic jockey wheel
- Protected front and rear lights
- Electro-hydraulic pump with battery
- Integrated ramps rack with strips for noise reduction
- Rectangular posts (no residue in the corners)
- 6 tie rings
- 4 removable aluminium drop sides 350 mm
- Removable front H-Frame galvanised steel

PW3.3

- 195/50R13C or 185R14C wheels
- Exclusive colour : black anodized alu side walls
- Integral cover for battery and hydraulic unit
- 8 tie rings

PW3.6

- 8 tie rings
- 195/50R13C or 185R14C wheels
- Integral cover for battery and hydraulic unit

PULLMAN 2

performance

PULLMAN 2 SUSPENSION

Developed in the R&D department of Cheval Liberté/ Debon, the PULLMAN 2 suspension frees you from the constraints of hitched transport and allows you to tow your trailer in complete safety while enjoying exceptional road comfort.

Suspension inspired by cars

Always closer to automotive technology, the PULLMAN 2 suspension, 4 independent wheels suspension is composed of 4 articulated arms on galvanized steel silentblocks associated with 4 large diameter springs and 4 hydraulic dampers.

**Pullman: performance
and comfort.**

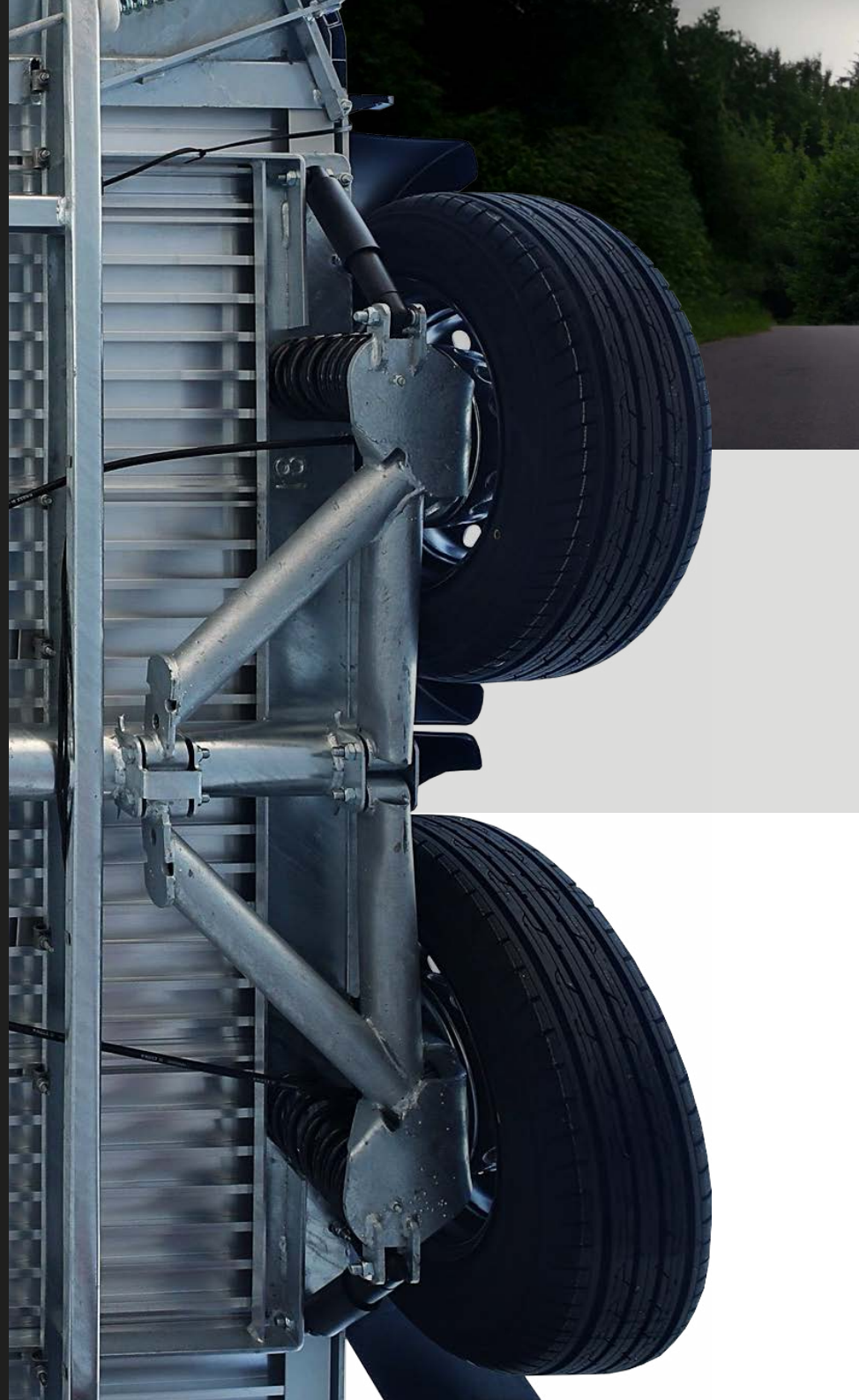



**Reduced vibration,
increased efficiency**



Spring
helical

+



Individual
suspension arm

+



Hydraulic
shock absorber

Optimised centre of gravity.

With a center of gravity placed as close to the road as possible, the Debon Trailers have an optimized ground clearance.

The trailers stick to the road and absorb the hazards of the road. Both unloaded and loaded, vibrations are considerably reduced, thus guaranteeing a remarkable comfort of use.

Certified quality.

The PULLMAN 2 suspension combined with the aerodynamic design of the Cheval Liberté vans offers a real comfort of traction and contributes to the significant reduction of the fuel consumption of the towing vehicle.

The PULLMAN suspension is recognized as the best suspension for vans and tippers.

It is recommended by all trailer professionals. In a few words, technology, safety and comfort perfectly sums up the performance of the Pullman 2 suspension.

PULLMAN²
performance

Standorte



WIEN

Am Stadtrand von Wien, 2km zur SCS
1230 Wien
Altmannsdorfer Str. 200

Bernhard Berger Tel. 0664 60 94 94 06



LIEBOCH

Direkt an der A2, Abfahrt Lieboch
8501 Lieboch
Johann-Humer-Straße 1

Alexander v. Ederen Tel. 0664 60 94 94 13



GUNSKIRCHEN

Am Stadtrand von Wels, Abfahrt Wels West
4623 Günskirchen bei Wels
Grünbach 10

Robert Bartulovic Tel. 0664 60 94 94 08
Herbert Hirschvogel Tel. 0664 60 94 94 02



KRAMSACH

Direkt an der A12, Abfahrt Kramsach
6233 Kramsach
Amerling 131a

Tamara Hägele Tel. 0699 12 78 60 44



BAD GOISERN (HUMER PARTNER)

Direkt an der B145
4822 Bad Goisern
Bundesstraße 47

Alex Putz Tel. 0664 76 77 51 9

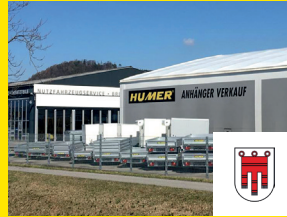

SULZ (HUMER PARTNER)

Direkt an der A14, Abfahrt Klaus
6832 Sulz
Industriestraße 2

Bernhard Schöch Tel. 0699 17 15 31 31



KLAGENFURT (HUMER PARTNER)

Am Stadtrand von Klagenfurt, Abfahrt Klagenfurt-Ost
St. Jakober Straße 40
9020 Klagenfurt am Wörthersee

László Illes Tel. 0463 477 67 12



Besuchen Sie uns auch auf
Facebook, Instagram und YouTube!

Debon Cheval Liberté Group

Since 1995



info@debon-trailers.com

debon-trailers.com



Your dealer

SARL Nancy Cheval - Vans Cheval Liberté et Remorques Debon - Route de St Baslemont - 88804 Lignéville Cedex

July 2025 - Non-binding documents